



Principles of Operation

Vortices are created when a fluid passes around a bluff body as shown below. Vortices are alternately shed on each side of the body, 180 degrees out of phase to each other, resulting in an oscillating pressure gradient. As flow increases the frequency of vortices increases in proportion to the increased flow thereby creating a linear relationship. Aalborg's unique dual signal processing technology independently measures each vortex on either side of the bluff body and filters out non-flow noise. This results in less noise and higher accuracy throughout the flow range.

Dual signal processing technology independently measures each vortex providing increased accuracy and turndown.



Vortex In-line Flow Meter Shown with Wafer Mounting

TABLE 29 - BENEFITS

RELIABLE	No moving parts to wear or fail. Electronics can be remote mounted up to 30.5 m (100 ft). No fluid to sensor contact. No holes to clog.
WIDE RANGEABILITY	High flow turndown ratio up to 80:1. Dual signal processing technology improves accuracy at low flows.
HIGH ACCURACY	±0.5% of rate. Increased noise cancellation as a result of dual signal processing technology.

TABLE 30 - FUNCTIONAL SPECIFICATIONS

FLUID TYPES	Steam, Gas, Liquid.
MAXIMUM PRESSURE	103 bar (1500 psig) with wafer mount See Table 40 for flange mount.
FLUID TEMPERATURE	-73° to 232 °C std./to 316 °C opt. (-100° to 450 °F std./to 600 °F opt).
LOW FLOW CUT-OFF	Adjustable: Set @min. per Tables 34 to 38.
HIGH FLOW CUT-OFF	Adjustable: Set @max. per Tables 34 to 38.
VOLTAGE	115 /230 VAC selectable or 24 VDC.
FREQUENCY	50 /60 Hz.
OUTPUTS	Analog: 4-20 mA DC into 600 ohm or less.
LINEAR RANGE	Reynolds number of >10,000.

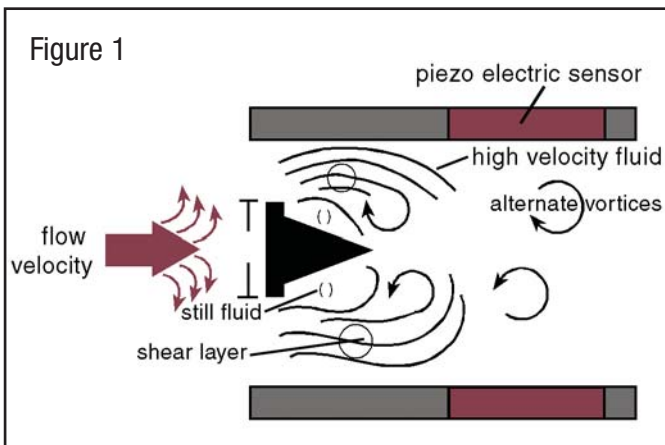

VORTEX IN-LINE FLOW METERS

TABLE 31 - PERFORMANCE SPECIFICATIONS

ACCURACY	± 0.5% of rate.
REPEATABILITY	± 0.25% of rate.
FLOW TURNDOWN RATIO	See Tables 34 to 38.
RESPONSE TIME	1000 ms.
DAMPING	Adjustable: 1 to 10 sec.
VELOCITY RANGE	Liq.: 1.32 or $\frac{10000\mu}{\bar{n}d \cdot 124}$ to 30 ft/sec Steam & Gas: $(144/\bar{n})^{1/3}$ to 250 ft/sec \bar{n} = density (lb/ft ³) d = pipe diameter (in) μ = viscosity (cp)
AGENCY APPROVALS*	FM and CSA Class 1 Div 2 Groups B,C,D.

* Designed to meet.
 Contact Aalborg for status of the agency approval.

**The selection of materials of construction, is the responsibility of the customer. The company accepts no liability.



Vortex In-line Flow Meter Shown with Flange Mounting

TABLE 32 - PHYSICAL SPECIFICATION

** MATERIALS OF CONSTRUCTION	
SHEDDER BAR	304 SS or 316 SS.
ELECTRODES	304 SS or 316 SS encapsulated ceramic.
METERING TUBE	304 SS or 316 SS.
FLANGES	304L SS or 316L SS.
ELECTRONICS HOUSING	Epoxy coated aluminum.
CONNECTIONS AND MOUNTINGS	
MOUNTING POSITION	Vertical, horizontal, angle.
TYPICAL STRAIGHT PIPE REQUIREMENTS	Upstream: 20 x D. Downstream: 5 x D.
TEMPERATURE TAP (BY CUSTOMER)	Downstream: 3.5 x D.
PRESSURE TAP (BY CUSTOMER)	Upstream: 3.5 x D.
PROCESS CONNECTIONS	ANSI Class 150 RF, 300 RF, 600 RF, Wafer.
ELECTRICAL CONNECT	3/4" FNPT.

TABLE 33 - ELECTRONIC SPECIFICATIONS

AMBIENT TEMPERATURE	-12° to 121 °C (-15° to 140 °F).
TRANSMITTER	Microprocessor-based.
DISPLAY	Two lines, simultaneous rate and total, 16 alphanumeric characters each.
FUNCTIONS	Zero, span, hi cutoff, low cutoff, response time, sample time, engineering units, totalizer, data logger, RS-232 interface.
OUTPUT SIGNAL	4-20mA output into 600 Ohm or less, 5V TTL Pulse Output. Use 18 or 20 gauge twisted pair shielded cable.
ENCLOSURE PROTECTION	NEMA 4X.
ENCLOSURE APPROVALS	UL, CSA, FM Class I Groups B, C, D Class II Groups E, F, G KEMA/CENELEC EEx d IIB
POWER SUPPLY	1530 VDC or 115 / 230 VAC (optional).

Flow Ranges

Minimum and maximum flow rates to achieve accuracy in Gal/min, L/min. Pipe ID based on schedule 80 steel.

TABLE 34 - WATER FLOW RATES AT 60 °F

SIZE (INCH)	3/4"		1"		1.5"		2"		3"		4"		6"	
	min	max	min	max	min	max	min	max	min	max	min	max	min	max
Gal/min	2.6	40.4	3.4	67.2	7.3	164.9	12.1	276.0	27.2	617.6	47.3	1075.3	107.2	2437.2
L/MIN	9.9	152.9	12.8	254.3	27.5	624.4	46.0	1044.9	102.9	2337.9	179.1	4070.4	405.9	9225.4

Minimum and maximum flow rates to achieve accuracy lb/hr. Pipe ID based on schedule 80 steel.

TABLE 35 - SATURATED STEAM FLOW RATES AT SELECTED PROCESS PRESSURES (English)

SIZE (INCH)	3/4"		1"		1.5"		2"		3"		4"		6"	
	min	max	min	max	min	max	min	max	min	max	min	max	min	max
Pressure (psig)														
10	8.7	83.6	14.5	203.5	35.7	668.1	59.7	1118.1	133.5	2501.7	232.5	4355.6	526.9	9871.7
25	11.7	129.9	19.5	316.0	48.0	1041.9	80.3	1743.5	179.6	3901.2	312.6	6792.1	708.6	15394.1
50	16.0	204.9	26.5	498.6	65.1	1649.3	109.0	2760.1	243.9	6175.9	424.7	10752.4	962.5	24369.8
75	19.6	278.5	32.6	677.7	80.0	2245.8	133.9	3758.3	299.6	8409.3	521.7	14640.7	1182.4	33182.7
100	22.9	351.3	38.1	854.8	93.4	2833.4	156.4	4741.7	349.9	10609.7	609.1	18471.6	1380.6	41865.3
125	25.9	423.5	43.1	1030	105.9	3417.8	177.2	5719.5	396.5	12797.7	690.2	22280.9	1564.4	50499.0
150	28.8	492.7	47.9	1199	117.6	4001.0	196.8	6695.5	440.4	14981.6	766.7	26083.1	1737.6	59116.4
200	34.1	639.2	56.8	1555	139.4	5160.8	233.2	8636.4	521.8	19324.6	908.5	33644.2	2059.0	76253.5
250	39.1	782.7	65.0	1904	159.6	6323.9	267.0	10582.9	597.5	23679.9	1040.3	41226.9	2357.8	93439.4
300	43.7	883.6	72.8	2150	178.6	7489.3	298.9	12533.1	668.8	28043.5	1164.5	48824.0	2639.2	110658.0
350	48.2	1057	80.2	2573	196.8	8663.4	329.4	14498.0	737.0	32440.2	1283.2	56478.6	2908.3	128006.8
400	52.5	1174	87.3	2857	214.3	9844.2	358.7	16474.0	802.6	36861.6	1397.3	64176.3	3166.9	145453.4
450	56.6	1316	94.2	3202	231.3	11036.0	387.1	18468.5	866.1	41324.3	1507.9	71945.9	3417.6	163062.9
500	60.7	1460	101.0	3552	247.8	12240.0	414.7	20483.2	928.0	45832.4	1615.7	79794.5	3661.9	180851.6
550	64.7	1605	107.5	3905	264.0	13456.0	441.8	22518.2	988.5	50385.9	1721.0	87722.2	3900.6	198819.5
600	68.5	1752	114.0	4262	279.8	14684.2	468.3	24573.6	1047.8	54984.8	1824.2	95729.0	4134.4	216966.5

Minimum and maximum flow rates to achieve accuracy in (kg/hr) Pipe ID based on schedule 80 steel.

TABLE 36 - SATURATED STEAM FLOW RATES AT SELECTED PROCESS PRESSURES (Metric)

Size (mm)	20		25		40		50		80		100		150	
Pressure (bara)	min	max	min	max	min	max	min	max	min	max	min	max	min	max
1	2.5	22.8	4.1	54.9	10.2	184.6	17.0	307.7	38.1	689.9	66.3	1201.7	150.2	2722.5
2	3.9	43.5	7.7	105	15.7	353.2	26.2	588.6	58.7	1319.8	102.2	2298.8	231.5	5207.9
4	5.9	84.0	11.9	206	24.2	676.6	40.4	1127.6	90.5	2528.2	157.6	4403.6	357.1	9976.5
6	7.7	123	15.3	300	31.2	991.3	52.1	1652.2	116.7	3704.3	203.3	6452.1	460.6	14617.3
10	10.6	200	21.2	489	43.2	1609.6	71.9	2682.6	161.3	6014.7	280.9	10476.3	636.3	23734.0
14	13.1	276	26.3	673	53.5	2222.3	89.2	3703.9	200.0	8304.4	348.3	14464.5	789.0	32769.4
18	15.5	353	30.9	862	62.9	2834.7	104.9	4724.5	235.2	10592.8	409.6	18450.4	928.0	41799.3
22	17.6	426	35.2	1037	71.7	3449.7	119.6	5749.5	268.1	12891.1	466.9	22453.5	1057.8	50868.4
26	19.7	505	39.3	1229	80.1	4069.0	133.5	6781.6	299.3	15205.0	521.2	26483.9	1180.9	59999.3
28	20.7	531	41.3	1294	84.1	4380.6	140.2	7300.9	314.4	16369.4	547.5	28512.0	1240.4	64594.0
30	21.6	569	43.3	1369	88.1	4693.7	146.8	7822.9	329.2	17539.8	573.3	30550.5	1298.9	69212.2
32	22.6	607	45.2	1461	92.0	5008.5	153.3	8347.5	343.7	18715.9	598.7	32599.0	1356.3	73853.0
34	23.5	637	47.1	1530	95.8	5325.0	159.7	8874.9	358.0	19898.5	623.6	34658.9	1412.9	78519.7
36	24.5	675	48.9	1622	99.6	5643.3	166.0	9405.5	372.2	21088.1	648.3	36731.0	1468.6	83214.0
38	25.4	713	50.8	1714	103.3	5963.7	172.2	9939.5	386.1	22285.4	672.6	38816.3	1523.7	87938.3
40	26.3	751	52.6	1806	107.0	6286.0	178.4	10476.7	399.9	23490.0	696.6	40914.5	1578.1	92691.7

Minimum and maximum flow rates to achieve accuracy in CFPM (14.7 psia 60 °F) CFM at actual process temperature = min. or max values below *520/ (Actual Temp. (°F) + 460) Pipe ID based on schedule 80 steel. Flow Temp. 60 °F.

TABLE 37 - AIR FLOW RATES AT SELECTED PROCESS PRESSURES (English)

Size (inch)	3/4"		1"		1.5"		2"		3"		4"		6"		
Density (lb/ft3)	Pressure (psig)	min	max	min	max	min	max	min	max	min	max	min	max	min	max
0.076	0	2.2	22.2	3.7	54.2	9.1	183.8	15.2	307.5	34.0	688.1	59.2	1197.9	134.1	2715.0
0.103	5	2.7	29.8	4.5	72.7	11.0	246.3	18.5	412.1	41.3	922.1	71.9	1605.3	163.0	3638.5
0.128	10	3.1	37.4	5.2	91.9	12.8	308.8	21.5	516.7	48.1	1156.1	83.7	2012.8	189.6	4561.9
0.180	20	3.9	52.6	6.6	128	16.1	433.8	26.9	725.9	60.3	1624.2	104.9	2827.7	237.8	6408.9
0.232	30	4.7	67.7	7.8	164	19.1	558.8	31.9	935.1	71.4	2092.2	124.2	3642.6	281.6	8255.8
0.284	40	5.3	82.9	8.9	201	21.8	683.8	36.5	1144.2	81.7	2560.3	142.2	4457.5	322.2	10102.8
0.336	50	6.0	98.1	9.9	238	24.4	808.8	40.8	1353.4	91.3	3028.4	159.0	5272.4	360.3	11949.7
0.388	60	6.6	113.2	10.9	275	26.8	933.8	44.9	1562.6	100.5	3496.4	175.0	6087.3	396.5	13796.6
0.440	70	7.1	128.4	11.9	312	29.2	1058.8	48.8	1771.8	109.3	3964.5	190.2	6902.2	431.2	15643.6
0.493	80	7.7	143.6	12.8	349	31.4	1183.8	52.6	1981.0	117.7	4432.5	204.9	7717.1	464.3	17490.5
0.545	90	8.2	158.7	13.7	386	33.6	1308.8	56.2	2190.2	125.8	4900.6	219.0	8532.0	496.4	19337.4
0.596	100	8.7	173.9	14.6	423	35.7	1433.8	59.8	2399.3	133.8	5368.7	232.9	9346.9	527.8	21184.4
0.649	110	9.2	189.1	15.4	460	37.7	1558.8	63.2	2608.5	141.3	5836.7	246.1	10161.8	557.7	23031.3
0.700	120	9.7	204.2	16.2	497	39.8	1683.8	66.5	2817.7	148.9	6304.8	259.2	10976.7	587.4	24878.3
0.752	130	10.2	219.4	17.0	534	41.7	1808.8	69.8	3026.9	156.2	6772.8	271.9	11791.6	616.2	26725.2
0.804	140	10.7	234.6	17.8	570	43.6	1933.8	73.0	3236.1	163.3	7240.9	284.2	12606.5	644.2	28572.1
0.856	150	11.1	249.7	18.5	607	45.5	2058.8	76.1	3445.3	170.2	7709.0	296.4	13421.4	671.7	30419.1
1.116	200	13.3	325.6	22.1	792	54.2	2683.8	90.8	4491.2	203.1	10049.3	353.6	17495.9	801.5	39653.8
1.636	300	17.1	477.2	28.5	1161	70.0	3933.8	117.1	6583.0	262.1	14729.9	456.3	25644.8	1034.2	58123.2

Minimum and maximum flow rates to achieve accuracy in M³/min (°C, 1.013 bar). M³/min at actual process temperature = minimum or maximum values below x 273 (actual temp (°C) + 273). Pipe ID based on schedule 80 steel. Flow Temp 0 °C.

TABLE 38 - AIR FLOW RATES AT SELECTED PROCESS PRESSURES (Metric)

Size (mm)		20		25		40		50		80		100		150	
Density (kg/m ³)	Pressure (barg)	min	max	min	max	min	max	min	max	min	max	min	max	min	max
1.293	0	0.05	0.63	0.09	1.53	0.22	5.21	0.37	8.69	0.83	19.48	1.44	33.92	3.27	76.86
1.93	0.5	0.07	0.94	0.12	2.30	0.29	7.78	0.48	12.97	1.08	29.08	1.88	50.66	4.27	114.76
2.568	1	0.09	1.26	0.14	3.07	0.35	10.35	0.58	17.26	1.31	38.69	2.28	67.39	5.16	152.66
3.844	2	0.11	1.89	0.18	4.60	0.46	15.49	0.76	25.82	1.71	57.90	2.98	100.85	6.75	228.47
5.12	3	0.14	2.52	0.22	6.14	0.55	20.64	0.92	34.39	2.07	77.11	3.61	134.31	8.17	304.28
6.39	4	0.16	3.15	0.26	7.68	0.64	25.78	1.07	42.96	2.40	96.32	4.19	167.77	9.48	380.09
7.67	5	0.18	3.78	0.29	9.21	0.73	30.92	1.21	51.53	2.71	115.54	4.72	201.24	10.70	455.90
8.95	6	0.20	4.41	0.32	10.75	0.80	36.06	1.34	60.10	3.00	134.75	5.23	234.70	11.86	531.71
10.22	7	0.21	5.05	0.35	12.29	0.88	41.20	1.46	68.67	3.28	153.96	5.72	268.16	12.96	607.52
11.5	8	0.23	5.68	0.38	13.82	0.95	46.34	1.58	77.24	3.55	173.17	6.19	301.63	14.01	683.33
12.77	9	0.25	6.31	0.41	15.36	1.02	51.48	1.70	85.80	3.81	192.38	6.64	335.09	15.03	759.14
14.05	10	0.27	6.94	0.44	16.89	1.09	56.62	1.81	94.37	4.06	211.59	7.07	368.55	16.02	834.95
15.32	11	0.28	7.57	0.46	18.43	1.15	61.76	1.92	102.94	4.30	230.81	7.49	402.01	16.98	910.76
16.6	12	0.30	8.20	0.49	19.97	1.21	66.91	2.02	111.51	4.54	250.02	7.90	435.48	17.90	986.57
17.88	13	0.31	8.83	0.51	21.50	1.28	72.05	2.13	120.08	4.77	269.23	8.30	468.94	18.81	1062.38
19.15	14	0.33	9.47	0.54	23.04	1.34	77.19	2.23	128.65	4.99	288.44	8.69	502.40	19.69	1138.19
22.98	17	0.37	11.36	0.61	27.65	1.51	92.61	2.51	154.35	5.63	346.08	9.81	602.79	22.24	1365.62
26.81	20	0.41	13.25	0.67	32.26	1.67	108.04	2.78	180.06	6.24	403.71	10.88	703.18	24.64	1593.05

Wafer Mounting

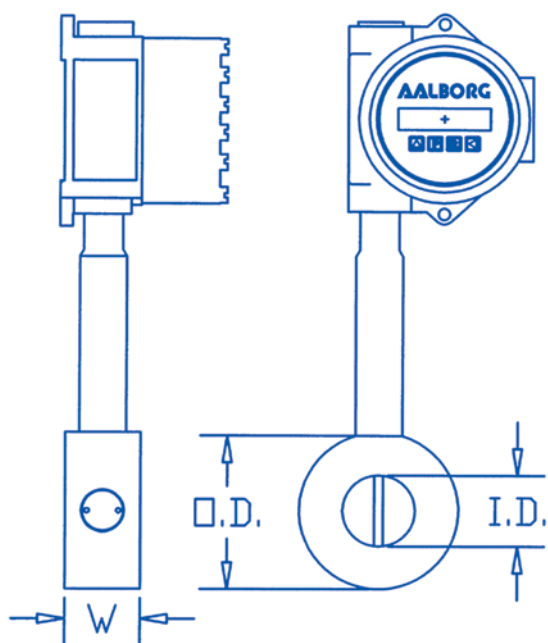

Flange Mounting

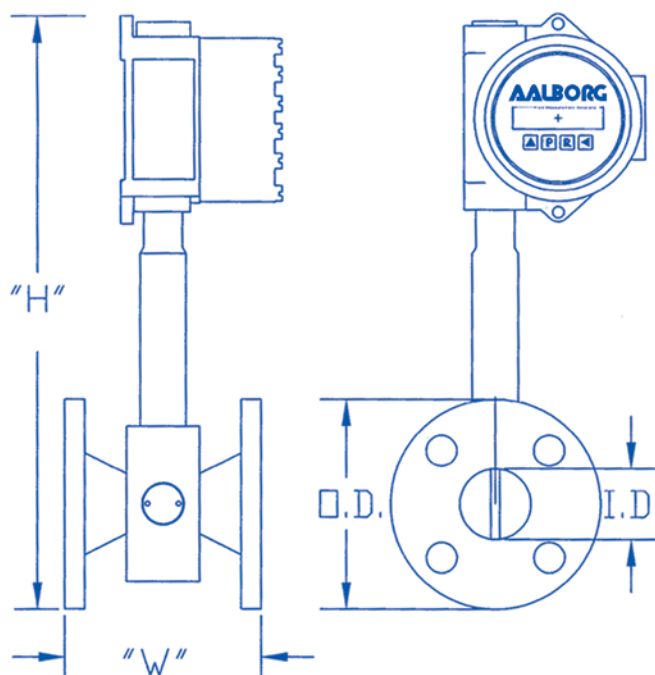



ANSI Flange Pressure - Temperature Ratings.
Maximum Pressure in psig.

MATERIAL	TEMP. °F					
	-100 to 100	200	300	400	500	600
304L SS/316L SS 150# RF	230	195	175	160	145	140
304L SS/316L SS 300# RF	600	505	455	415	380	360
304L SS/316L SS 600# RF	1200	1015	910	825	765	720
304L SS/316L SS 900# RF	1500	1500	1360	1240	1145	1080
304L SS/316L SS 1500# RF	1500	1500	1500	1500	1500	1500

Meter Size	Flange Rating	Bolt diameter	Bolts	I.D.	O.D.	“W”	“H”
in.	psi	in.	no.	in.	in.	in.	in.
3/4	150	1/2	4	0.742	3.875	5.88	9.75
	300	5/8	4		4.625	6.25	10.125
	600	5/8	4		4.625	6.25	10.125
	900	7/8	4		5.125	7.25	10.375
	1500	7/8	4		5.125	7.25	10.375
1	150	1/2	4	0.957	4.25	6.13	9.95
	300	5/8	4		4.875	6.63	10.27
	600	5/8	4		4.875	6.63	10.27
	900	1	4		5.875	7.5	10.76
	1500	1	4		5.875	7.5	10.76
1.5	150	1/2	4	1.50	5.00	6.63	10.35
	300	3/4	4		6.125	7.13	10.91
	600	3/7	4		6.125	7.25	10.91
	900	1-1/8	4		7.00	8.25	11.35
	1500	1-1/8	4		7.00	8.25	11.35
2	150	5/8	4	1.937	6.00	6.75	10.875
	300	5/8	4		6.50	7.25	11.125
	600	5/8	4		6.50	7.50	11.125
	900	1	4		8.50	9.75	12.125
	1500	1	4		8.50	9.75	12.125
3	150	5/8	4	2.900	7.50	7.25	11.60
	300	3/4	8		8.25	8.00	11.98
	600	3/4	8		8.25	8.25	11.98
	900	1	8		9.50	9.75	12.60
	1500	1-1/4	8		10.50	11.00	13.10
4	150	5/8	4	3.826	9.00	8.25	12.37
	300	3/4	8		10.00	9.00	12.87
	600	7/8	8		10.75	10.25	13.25
	900	1-1/4	8		11.50	11.285	13.62
	1500	1-3/8	8		12.125	12.00	13.93
6	150	3/4	8	5.761	11.00	9.75	14.31
	300	7/8	12		12.50	10.50	15.06
	600	1	12		14.00	12.00	15.81
	900	1-1/4	12		15.00	13.75	16.31
	1500	1-1/2	12		15.50	16.25	16.65

Meter Size	Flange Rating	Bolt diameter	Bolts	I.D.	O.D.	“W”	“H”
in.	psi	in.	no.	in.	in.	in.	in.
3/4	150	1/2	4	0.742	2.370	2	9.00
	300	5/8	4				
	600	5/8	4				
1	150	1/2	4	0.957	2.740	2	9.20
	300	5/8	4				
	600	5/8	4				
1.5	150	1/2	4	1.500	3.500	2	9.60
	300	3/4	4				
	600	3/4	4				
2	150	5/8	4	1.937	4.250	2	10.00
	300	5/8	8				
	600	5/8	8				
3	150	5/8	4	2.900	5.497	2	10.60
	300	3/4	8				
	600	3/4	8				
4	150	5/8	8	3.826	6.997	2.5	11.37
	300	3/4	8				
	600	7/8	8				
6	150	3/4	8	5.761	8.872	3	13.25
	300	7/8	12				
	600	1	12				

Ambient Temperature Range for Electronics

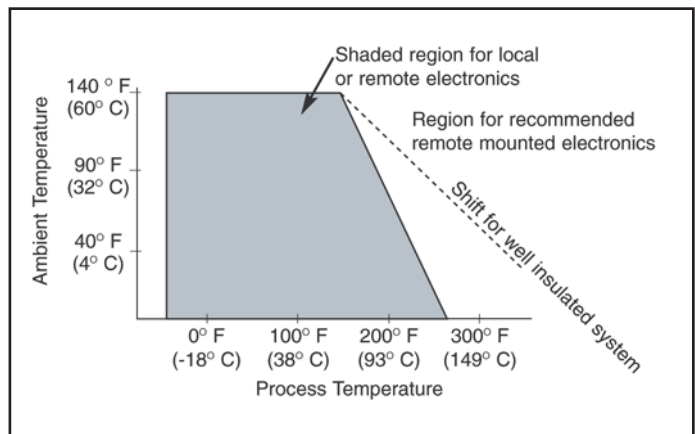



TABLE 42 - BENEFITS	
RELIABLE	No moving parts to wear or fail. Electronics can be remote mounted up to 100 ft. (30.5 m) No fluid to sensor contact. No holes to clog.
WIDE RANGEABILITY	High flow turndown ratio up to 80:1. Dual signal processing technology improves accuracy at low flows.
HIGH ACCURACY	± 0.5% of rate. Increased noise cancellation as a result of dual signal processing technology.

Principles of Operation

Vortices are created when a fluid passes around a bluff body as shown below. Vortices are alternately shed on each side of the body, 180 degrees out of phase to each other, resulting in an oscillating pressure gradient. As flow increases the frequency of vortices increases in proportion to the increased flow thereby creating a linear relationship. Aalborg's unique dual signal processing technology independently measures each vortex on either side of the bluff body and filters out non-flow noise. This results in less noise and higher accuracy throughout the flow range.

Vortex Insertion Flow Meter Shown with Retractable Mounting

Vortex Insertion Flow Meter Shown with Fixed Mounting

TABLE 43 - FUNCTIONAL SPECIFICATIONS	
FLUID TYPES	Steam, Gas, Liquid.
MAXIMUM PRESSURE	1500 psig (103 bar) see Table 47 for flange ratings.
FLUID TEMPERATURE	-100° to 450 °F std. to 600 °F opt. (-73° to 232 °C std., to 316 °C opt.)
LOW FLOW CUT-OFF	Adjustable: Set @min. per Tables 48 to 50.
HIGH FLOW CUT-OFF	Adjustable: Set @max. per Tables 48 to 50.
VOLTAGE	15÷30 VDC or 115/230 VAC (optional).
FREQUENCY	50/60 Hz.
OUTPUTS	Analog: 4-20 mA DC into 600 ohm or less.
LINEAR RANGE	Reynolds number of >10,000.

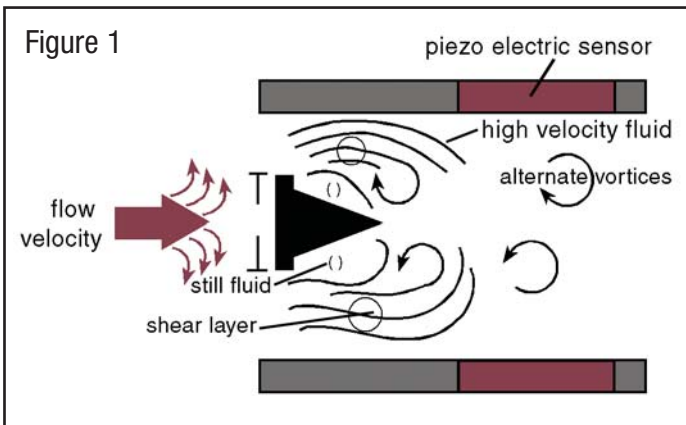

Dual signal processing technology independently measures each vortex providing increased accuracy and turndown.



TABLE 44 - PERFORMANCE SPECIFICATIONS

ACCURACY	± 0.5% of rate.
REPEATABILITY	± 0.25% of rate.
FLOW TURNDOWN RATIO	See Tables 48 to 50.
RESPONSE TIME	1000 ms.
DAMPING	Adjustable: 1 to 10 sec.
VELOCITY RANGE	Liq.: 1.32 or $\frac{10000\mu}{\rho d \cdot 124}$ to 30 ft/sec Steam & Gas: (144/r) $\frac{1}{3}$ to 250 ft/sec ρ = density (lb/ft ³) d = pipe diameter (in) μ = viscosity (cp)
AGENCY APPROVALS*	FM and CSA Class 1 Div 2 Groups B,C,D.

*Designed to meet.
 Contact Aalborg for status of the agency approval.

**The selection of materials of construction, is the responsibility of the customer. The company accepts no liability.

TABLE 45 - PHYSICAL SPECIFICATIONS

**MATERIALS OF CONSTRUCTION	
SHEDDER BAR	304 SS or 316 SS.
ELECTRODES	304 SS or 316 SS encapsulated ceramic.
METERING TUBE	304 SS or 316 SS.
FLANGES	304L SS or 316L SS.
ELECTRONICS HOUSING	Epoxy coated aluminum.
CONNECTIONS AND MOUNTINGS	
MOUNTING POSITION	Vertical, horizontal, angle.
TYPICAL STRAIGHT PIPE REQUIREMENTS	Upstream: 20 x D. Downstream: 5 x D.
PROCESS CONNECTIONS	MNPT, ANSI Class 150 RF, 300 RF, 600 RF, Welded Flange.
ELECTRICAL CONNECT	3/4" FNPT.

TABLE 46 - ELECTRONIC SPECIFICATIONS

AMBIENT TEMPERATURE	-15° to 140 °F (-12° to 121 °C).
TRANSMITTER	Microprocessor-based.
DISPLAY	Two lines, simultaneous rate and total, 16 alphanumeric characters each.
FUNCTIONS	Zero, span, hi cutoff, low cutoff, flow rate units, response time, sample time, and engineering units, data logger, RS-232 interface.
OUTPUT SIGNAL	4-20mA into 600 Ohm or less. 5V TTL pulse output. Use 18 or 20 gauge twisted pair shielded cable.
ENCLOSURE PROTECTION	NEMA 4X/IP 66.
ENCLOSURE APPROVALS*	UL, CSA, FM Class I Groups B, C, D Class II Groups E, F, G KEMA/CENELEC EEx d IIB

*Designed to meet.
 Contact Aalborg for status of the agency approval.

Ambient Temperature Range for Electronics

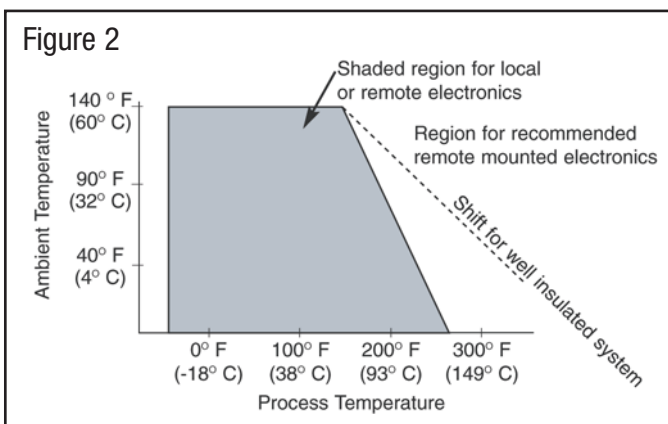



Flow Meter Pressure Rating

ANSI Flange Pressure - Temperature Ratings. Maximum Pressure in psig.

TABLE 47 - FLOW METER PRESSURE RATING

MATERIAL	TEMP. °F					
	-100 to 100	200	300	400	500	600
304L SS/316L SS 150# RF	230	195	175	160	145	140
304L SS/316L SS 300# RF	600	505	455	415	380	360
304L SS/316L SS 600# RF	1200	1015	910	825	765	720
304L SS/316L SS 900# RF	1500	1500	1360	1240	1145	1080
304L SS/316L SS 1500# RF	1500	1500	1500	1500	1500	1500

Flow Ranges

Minimum and maximum flow rates to achieve accuracy. Pipe ID based on schedule 40 steel.

TABLE 48 - WATER FLOW RATES AT 60 °F

	4"		5"		6"		8"		10"		12"		14"	
	min	max	min	max	min	max	min	max	min	max	min	max	min	max
Gal/min	52.4	1190.3	82.4	1871.6	118.8	2701.1	205.7	4675.0	324.4	7372.0	460.5	10466.3	556.6	12648.9
L/MIN	198.2	4505.6	311.7	7084.7	449.9	10224.3	778.6	17696.4	1227.8	27905.4	1743.2	39618.1	2106.7	47880.1

	16"		18"		20"		24"		30"		36"	
	min	max	min	max	min	max	min	max	min	max	min	max
Gal/min	727.1	16524.1	920.3	20915.1	1143.7	25994.0	1654.2	37595.4	2624.5	59648.2	3845.6	59648.2
L/MIN	2752.2	62549.0	3483.5	79169.9	4329.4	98395.3	6261.6	142310.1	9934.6	225786.9	14556.7	330833.6



Minimum and maximum flow rates to achieve accuracy in (lb/hr).
Pipe ID based on schedule 40 steel.

TABLE 49 - SATURATED STEAM FLOW RATES AT SELECTED PROCESS PRESSURES (English)

Pressure (psig)	4"		6"		8"		10"		12"		14"		16"		18"		20"	
	min	max	min	max	min	max	min	max	min	max	min	max	min	max	min	max	min	max
10	257.3	4821.3	404.7	7581.1	584.0	10940.7	1011.4	18947.2	1593.9	29860.7	2262.9	42393.9	2734.8	51234.9	3572.6	66931.5	4522.0	84717.0
25	346.1	7518.4	544.2	11822.0	785.3	17061.0	1360.0	29546.4	2143.4	46564.9	3043.0	66109.4	3677.6	79896.0	4804.3	104373.4	6080.9	132108.2
50	470.1	11902.2	739.1	18715.0	1066.7	27008.8	1847.3	46773.9	2911.4	73715.4	4133.3	104655.7	4995.3	126480.8	6525.7	165230.2	8259.7	209136.3
75	577.5	16206.4	908.0	25482.9	1310.4	36776.0	2269.4	63688.8	3576.6	100373.2	5077.8	142502.4	6136.7	172220.2	8016.8	224982.6	10147.0	284766.5
100	674.3	20446.9	1060.2	32150.7	1530.1	46398.8	2649.8	80353.6	4176.0	126636.8	5928.8	179789.5	7165.2	217283.2	9360.4	283851.4	11847.7	359278.3
125	764.0	24663.6	1201.4	38781.0	1733.8	55967.4	3002.6	96924.6	4732.0	152752.5	6718.2	216866.7	8119.2	262092.6	10606.7	342388.8	13425.2	433370.7
150	848.7	28872.3	1334.4	45398.8	1925.8	65518.0	3335.1	113464.3	5256.1	178819.0	7462.3	253874.0	9018.4	306817.4	11781.4	400815.8	14912.0	507323.3
200	1005.6	37242.0	1581.2	58559.3	2282.0	84510.8	3952.0	146356.1	6228.3	230656.3	8842.4	327468.7	10686.4	395759.8	13960.4	517007.1	17670.0	654389.8
250	1151.5	45635.6	1810.7	71757.4	2613.1	103557.7	4525.4	179341.8	7132.0	282641.4	10125.5	401273.4	12237.1	484955.9	15986.2	633529.7	20234.1	801875.6
300	1289.0	54045.1	2026.8	84980.4	2925.0	122640.8	5065.6	212389.9	7983.3	334725.1	11334.1	475217.9	13697.7	574321.0	17894.2	750273.3	22649.2	949641.0
350	1420.4	62518.2	2233.5	98303.6	3223.3	141868.3	5582.1	245688.2	8797.3	387203.0	12489.7	549722.1	15094.4	664362.5	19718.8	867900.4	24958.6	1098524.8
400	1546.7	71039.1	2432.1	111701.8	3509.9	161204.2	6078.4	279174.1	9579.5	439976.5	13600.3	624646.1	16436.5	754911.2	21472.1	986190.2	27177.8	1248247.4
450	1669.2	79639.6	2624.6	125225.1	3787.7	180720.5	6559.6	312972.7	10337.8	493242.8	14676.9	700269.6	17737.7	846305.5	23171.9	1105584.5	29329.3	1399368.0
500	1788.4	88327.5	2812.2	138886.0	4058.4	200435.5	7028.4	347115.1	11076.6	547051.1	15725.8	776662.6	19005.3	938629.7	24827.9	1226193.7	31425.3	1552026.3
550	1905.0	97103.0	2995.5	152684.6	4322.9	220349.1	7486.5	381601.5	11798.7	601401.4	16750.9	853825.2	20244.1	1031883.9	26446.2	1348017.8	33473.7	1706222.4
600	2019.2	105966.0	3175.1	166620.7	4582.1	240461.2	7935.4	416431.9	12506.1	656293.7	17755.2	931757.3	21458.0	1126068.2	28031.9	1471056.9	35480.8	1861956.2

Minimum and maximum flow rates to achieve accuracy in (kg/hr).
Pipe ID based on schedule 40 steel.

TABLE 50 - SATURATED STEAM FLOW RATES AT SELECTED PROCESS PRESSURES (Metric)

Line Size (mm)	100		150		200		250		300		350		400		450		500	
	min	max	min	max	min	max	min	max	min	max	min	max	min	max	min	max	min	max
1	73.4	1329.7	115.4	2090.9	166.6	3018.9	288.4	5226.4	454.5	8237.2	645.3	11695.0	779.9	14134.1	1018.9	18464.4	1289.6	23370.9
2	113.1	2543.6	177.8	3999.7	256.7	5774.9	444.4	9997.6	700.4	15757.0	994.5	22371.5	1201.9	27037.3	1570.1	35320.7	1987.3	44706.4
4	174.4	4872.5	274.2	7661.9	396.0	11062.5	685.5	19151.7	1080.4	30184.5	1533.9	42855.4	1853.8	51793.3	2421.7	67661.2	3065.3	85640.8
6	225.0	7139.1	353.8	11226.0	510.8	16208.6	884.3	28060.7	1393.7	44225.8	1978.7	62790.8	2391.4	75886.4	3124.1	99135.8	3954.2	125479.1
10	310.8	11591.7	488.7	18227.6	705.6	26317.8	1221.6	45561.9	1925.3	71809.1	2733.5	101953.1	3303.6	123216.3	4315.8	160966.2	5462.6	203739.6
14	385.4	16004.6	606.0	25166.8	874.9	36336.8	1514.7	62907.1	2387.3	99146.5	3389.4	140766.2	4096.3	170124.2	5351.3	222245.3	6773.2	281302.3
18	453.2	20414.8	712.7	32101.7	1029.1	46349.7	1781.5	80241.7	2807.8	126467.1	3986.5	179555.5	4817.9	217003.3	6293.9	283486.8	7966.4	358817.5
22	516.6	24844.1	812.4	39066.7	1173.0	56406.1	2030.7	97651.6	3200.5	153906.4	4544.0	218513.1	5491.7	264085.9	7174.2	344994.2	9080.6	436669.2
26	576.7	29303.6	906.9	46079.1	1309.4	66531.0	2266.9	115180.0	3572.9	181532.6	5072.7	257736.3	6130.7	311489.3	8008.9	406920.6	10137.1	515051.3
28	605.8	31547.7	952.6	49607.9	1375.5	71625.9	2381.3	124000.5	3753.0	195434.2	5328.5	277473.6	6439.8	335343.0	8412.7	438082.4	10648.3	554493.7
30	634.4	33803.2	997.5	53154.6	1440.3	76746.9	2493.4	132866.0	3929.9	209407.1	5579.5	297311.9	6743.2	359318.8	8809.1	469403.7	11149.9	594138.1
32	662.4	36069.8	1041.6	56718.8	1504.0	81893.0	2603.7	141775.0	4103.6	223448.3	5826.2	317247.4	7041.3	383412.0	9198.6	500878.3	11642.9	633976.3
34	690.0	38349.0	1085.1	60302.8	1566.7	87067.6	2712.2	150733.5	4274.7	237567.6	6069.2	337293.7	7334.9	407639.2	9582.1	532528.0	12128.4	674036.3
36	717.3	40641.7	1127.9	63908.0	1628.5	92273.0	2819.3	159745.2	4443.4	251770.7	6308.7	357458.9	7624.4	432010.0	9960.3	564365.3	12607.1	714333.7
38	744.2	42949.1	1170.2	67536.2	1689.6	97511.6	2925.0	168814.4	4610.1	266064.4	6545.3	377752.9	7910.3	456536.4	10333.8	596405.9	13079.8	754888.5
40	770.8	45270.6	1212.0	71186.8	1749.9	102782.4	3029.5	177939.3	4774.7	280446.1	6779.1	398171.6	8192.9	481213.7	10703.0	628643.6	13547.0	795692.6



Minimum and Maximum Flow Rates to achieve Accuracy in CFPM (177 PSIA and 60 °F).
 PipeID Based on Schedule 40 Steel.

TABLE 51 - AIR FLOW RATES AT 60 °F CONDITIONS

DENSITY (lb/ft ³)	PRESSURE (PSIG)	4"		6"		8"		10"		12"		14"	
		min	max	min	max	min	max	min	max	min	max	min	max
0.076	0	59.2	1197.9	134.1	2715	257.4	5211	405	8214	576	11659	696	14093
0.103	5	71.9	1605.3	163.0	3638	312.9	6983	493	11007	700	15625	846	18887
0.128	10	83.7	2012.8	189.6	4562	363.8	8756	573	13802	814	19591	984	23681
0.180	20	104.9	2827.7	237.8	6409	456.4	12301	719	19389	1021	27523	1234	33268
0.232	30	124.2	3642.6	281.6	8256	540.3	15846	852	24977	1209	35454	1461	42855
0.284	40	142.2	4457.5	322.2	10103	618.2	19391	974	30564	1383	43386	1672	52443
0.336	50	159.0	5272.4	360.3	11950	691.4	22936	1089	36152	1547	51317	1870	62030
0.388	60	175.0	6037.3	396.5	13797	760.9	26481	1199	41740	1702	59249	2058	71618
0.440	70	190.2	6902.2	431.2	15644	827.4	30026	1304	47328	1851	67181	2238	81205
0.493	80	204.9	7717.1	464.3	17490	891.3	33571	1405	52915	1994	75113	2410	90792
0.545	90	219.0	8532.0	496.4	19337	952.9	37116	1502	58504	2132	83044	2577	100379
0.596	100	232.9	9346.9	527.8	21184	1021.7	40661	1596	64091	2265	90976	2739	109967
0.649	110	246.1	10161.8	557.7	23031	1070.8	44206	1688	69979	2396	98907	2896	119554
0.700	120	259.2	10976.7	587.4	24878	1127.3	47751	1777	75266	2522	106839	3049	129142
0.752	130	271.9	11791.6	616.2	26725	1182.4	51296	1864	80854	2645	114771	3198	138729
0.804	140	284.2	12606.5	644.2	28572	1236.3	54841	1949	86442	2766	122703	3343	148317
0.856	150	296.4	13421.4	671.7	30419	1289.0	58386	2032	92030	2884	130634	3486	157904
1.116	200	353.6	17495.9	801.5	39654	1538.2	76111	2425	119968	3442	170293	4160	208841
1.636	300	456.3	25644.8	1034.2	58123	1984.9	111560	3129	175846	4441	249609	5368	301714

DENSITY (lb/ft ³)	PRESSURE (PSIG)	16"		18"		20"		24"		30"		36"	
		min	max	min	max	min	max	min	max	min	max	min	max
0.076	0	909	18407	1151	23300	1430	28953	2068	41875	3458	69995	4810	97377
0.103	5	1105	24669	1399	31225	1738	38800	2514	56118	4203	93803	5847	130498
0.128	10	1285	30930	1627	39150	2021	48648	2924	70362	4887	117611	6799	163620
0.180	20	1612	43452	2040	55000	2536	68344	3667	98848	6130	165227	8528	229863
0.232	30	1908	55974	2416	70851	3002	88039	4342	127335	7257	212843	10096	296106
0.284	40	2184	68497	2764	86701	3434	107735	4967	155821	8303	260459	11551	362348
0.336	50	2442	81019	3091	102552	3841	127431	5555	184308	9287	308075	12919	428591
0.388	60	2688	93541	3402	118402	4227	147127	6114	212794	10220	355691	14218	494834
0.440	70	2923	106063	3699	134253	4597	166822	6649	241281	11113	403307	15461	561077
0.493	80	3148	118586	3985	150103	4952	186518	7162	269767	11972	450923	16655	627320
0.545	90	3366	131108	4261	165953	5295	206214	7658	298254	12800	498539	17809	693503
0.596	100	3577	143630	4528	181804	5627	225909	8138	326741	13603	546155	18924	759806
0.649	110	3782	156152	4788	197654	5949	245605	8604	355227	14383	593771	20009	826048
0.700	120	3982	168675	5040	213505	6263	265301	9058	383713	15142	641387	21065	892291
0.752	130	4177	181197	5287	229355	6569	284996	9502	412200	15882	689003	22095	958534
0.804	140	4367	193719	5528	245205	6869	304692	9934	440687	16606	736619	23102	1042777
0.856	150	4553	206242	5763	261056	7162	324387	10358	469173	17314	784235	24087	1091020
1.116	200	5434	268853	6878	340307	8546	422866	12361	611606	20661	1022315	28744	1422234
1.636	300	7011	394076	8875	498812	11028	619823	15950	896471	26661	1498474	37090	2084663



Flanged Insertion Meter

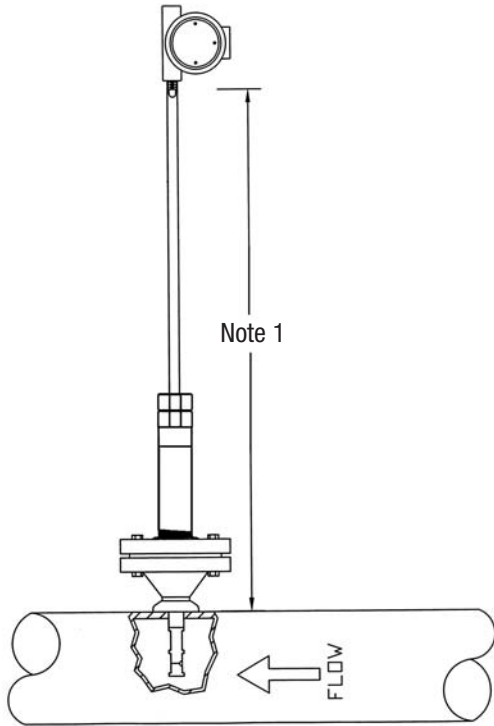

1-1/2" MNPT Insertion Meter

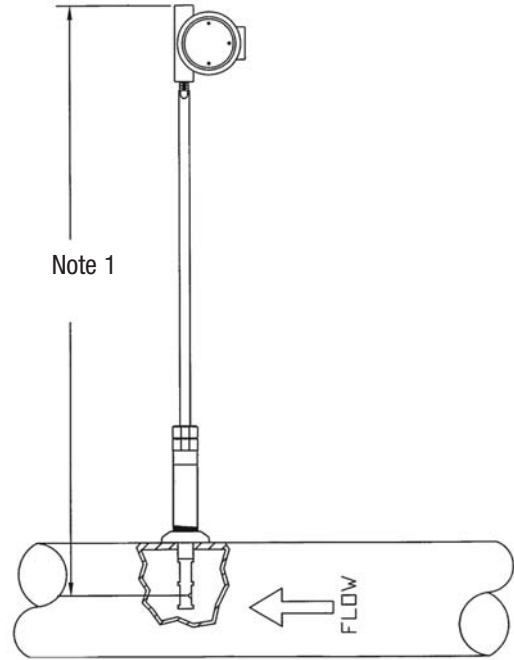

1-1/2" Insertion Meter Assembly with Insertion Tool and Ball Valve

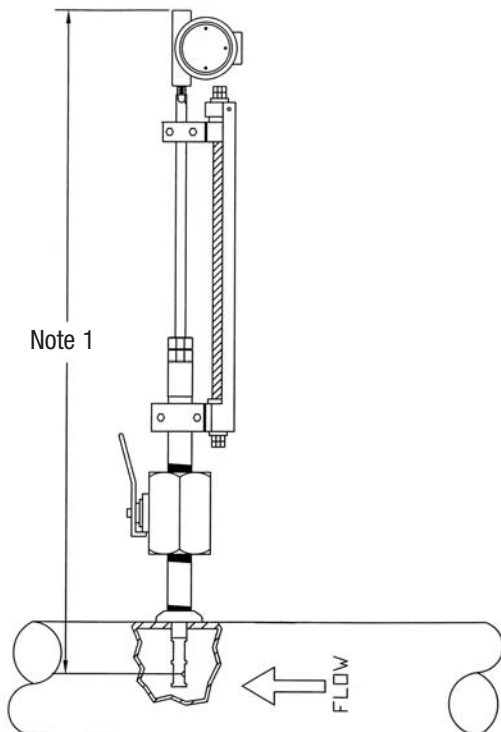

1-1/2" Welded Insertion Meter

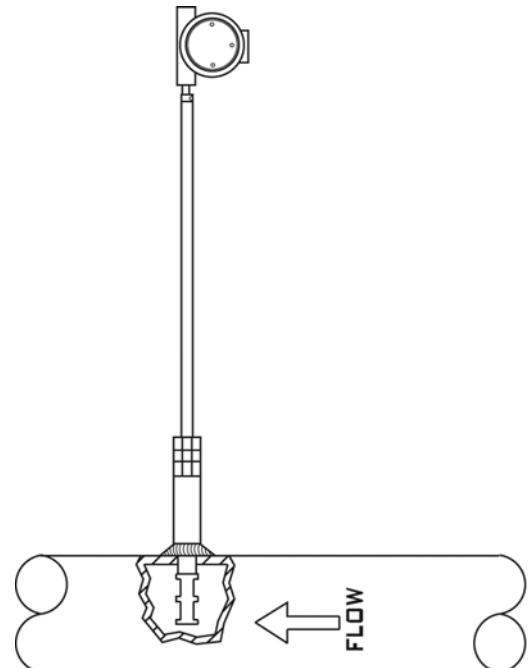

Note 1: Length dependent on pipe diameter, thickness, and mounting.



MODEL	
VX	
STYLE	
W	Wafer
F	Flange
I	Insertion
SIZE: WAFER or FLANGE	
07	3/4" (20mm)
10	1.0" (25mm)
15	1.5" (40mm)
20	2.0" (50mm)
30	3.0" (80mm)
40	4.0" (100mm)
60	6.0" (150mm)
SIZE: INSERTION	
04"-36"	PIPE DIAMETER
FLUID TYPE	
G	Gas
L	Liquid
S	Steam
MAX TEMP.	
4	450 °F
6	600 °F
MATERIAL	
S4	304 SS
S6	316 SS
MOUNTING CONNECTION	
A	Wafer. Using Customer Flanges.
B	Flange Mounting.
C	Insertion with Flange.
D	Insertion. With 1.5 MNPT Thread.
E	Insertion, Welded.
F	Other.
FLANGE RATING†	
A	150# ANSI RF (Alignment Rings Not Required for Wafer Style)
B	300# ANSI RF (Wafer Style Includes Alignment Rings)
C	600# ANSI RF (Wafer Style Includes Alignment Rings)
D	OTHER
N	NONE
DISPLAY	
L	Local
R	Remote
POWER	
04	24VDC
12	120VAC
22	220VAC

To allow us to confirm selection please return completed application data sheet found on Aalborg's web site at www.aalborg.com.

1. Select style (wafer, flange or insertion).
2. Select meter size to match internal pipe diameter (for insertion style select pipe diameter).
3. Confirm minimum and maximum flow ranges to maintain stated accuracy from liquid, steam, or air from Tables 34 to 38 are within your requirements.
4. For other gas applications consult factory.
5. Select fluid type.
6. Select maximum temperature capability.
7. Select desired **Material of Construction.
8. Select mounting connection.
9. Confirm maximum pressure capability of flange/meter rating with process conditions and select flange rating from Table 39.
10. Confirm suitability of standard local mounted electronics.
11. Select desired transmitter power.
12. Provide: Fluid, Fluid Viscosity, Minimum & Maximum Operating Pressure, Minimum & Maximum Operating Temperature, Density/Specific Gravity or Specific Volume.
13. Provide minimum and maximum flow range.

Options: Remote mount electronics up to 100 ft. (30.5 m).

† = Flange and Insertion Style. Wafer Style for Alignment Ring Selection.
 ** = The selection of materials of construction, is the responsibility of the customer. The company accepts no liability.

VX	W	10	L	4	S4	A	B	L	22
----	---	----	---	---	----	---	---	---	----

EXAMPLE: VXW-10L-4S4AB-L22

SPECIFY: FLUID NAME OR MEASURING DENSITY, FLOW RATE, and PRESSURE (STEAM, GASES).

Vortex meter, Wafer style, 10" diameter size, Liquid at maximum 450 °F, 304 stainless steel, Customer flanges, Flange 300# ANSI RF, Local display, 220V power.